

注：原理图中注释说明设计时需特别注意

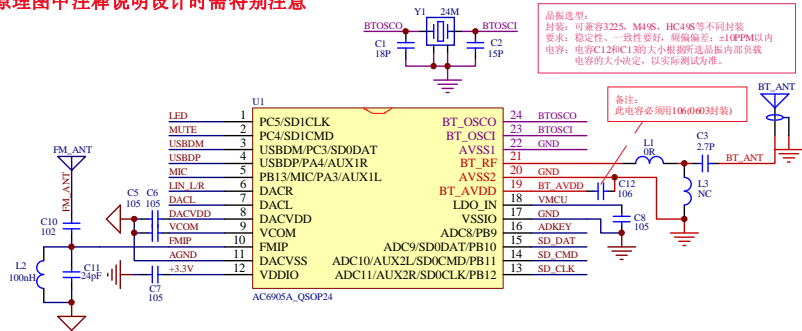

MCU

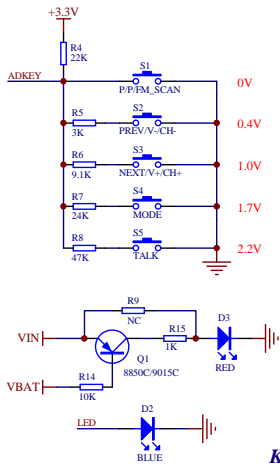
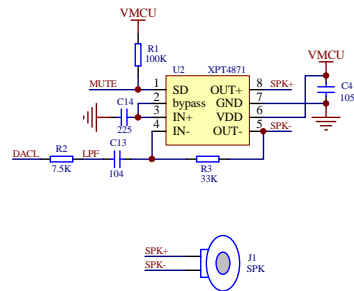

Key, LED

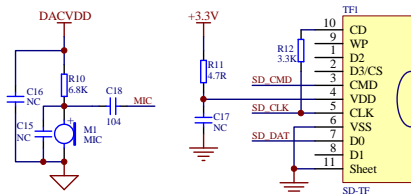

MIC, TF-CARD

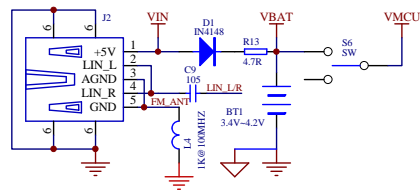

PA, Power